



desk SF.

Eco-Friendly Lighting :

Sustainable hardwood, ecologically made desk lamp incorporating an ultra-bright, single 3W super-flux LED light head.

ECO-DESK SF FEATURES :

- * Ultra-bright, single 3W LED and incorporated driver.
- * 'Cool' or 'Warm' white LED options.
- * Precision machined and turned, black or silver anodised aluminium fittings.
- * Sustainable and ecologically sourced black walnut frame and shade.
- * 12VDC compact mains transformer.
- * Low power consumption.
- * Maintenance free 100,000 hour LED runtime.
- * Made in England following stringent environmental policies.



ECO-DESK SF ACCESSORIES :

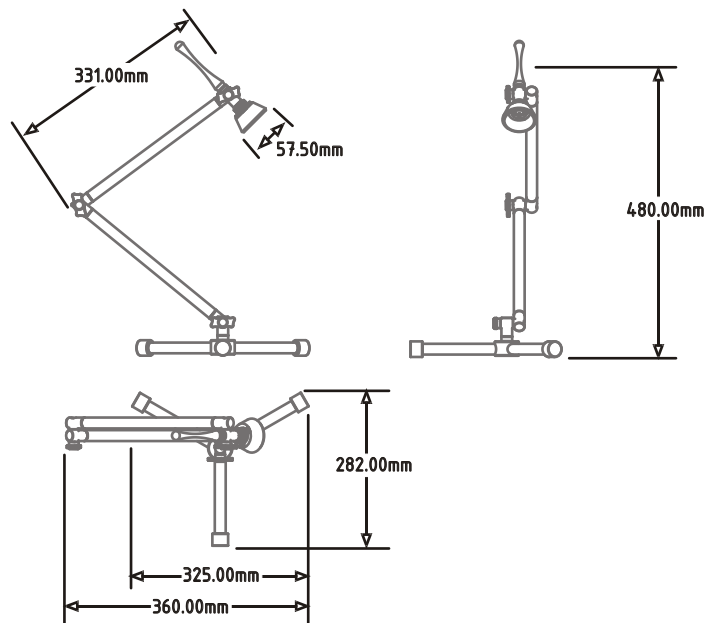

ECO-DESK SF SPECIFICATIONS :

OPTICAL :

Illumination Type : 3W super-flux 'cool' white or 3W super-flux 'warm' white LED.
Luminous Ratings : 800 Lux @ 0.5m ('cool' white), 900 Lux @ 0.5m ('warm' white). Approximate values

ELECTRICAL :

Power source : 230VAC to 12VDC, 500mA mains compact 'plug-in' power adapter (supplied)
Power consumption : 3W
Control : Switch point controls power on/off.
Cable : Resistant polyurethane. Length : 5m.
Switch rating : 250VAC 3A.

MECHANICAL :

Material : Sustainably sourced black walnut (main stand and shade), 6063 Aluminium (end fittings & knobs).
Finish : Natural beeswax (wood), anodised aluminium to AA25.
Weight : 0.47Kg.
Environment / IP Rating : Indoor / -

OPTIONS :

- * Desk stand (shown) or optional bench clamp.
- * ECO lamps can also be made in a variety of other woods to order. Please contact us for more details.

Luminaire

products * design



SUPER ENERGY EFFICIENT & ULTRA-BRIGHT SUPER-FLUX LED

WALNUT* FRAME & SHADE FROM SUSTAINABLY MANAGED SOURCE

www.luminair.co.uk

product : eco desk SF specification sheet - SP.LED-002-01.

Luminair Ltd.

24a Temple Street, Brighton, East Sussex. BN1 3BH. - tel / fax : 01273 383435. email : info@luminair.co.uk. web : www.luminair.co.uk. - E&OE. Information is subject to change without notice. Copyright © 2000-2006 Luminair Ltd.